

# Biscuit People Conference

## Designing and building baking ovens



**bakerpacific**

## The baking process

From dough pieces to biscuits

Heat transfer

Oven designs

Heat recovery system

## Baker Pacific local oven manufacture

Why build the oven locally?

The team

Oven building

- Manufacturing drawings
- Purchasing
- Contractors
- Shipping
- Installation



## From the dough piece to the biscuit

There are three main stages in the baking process

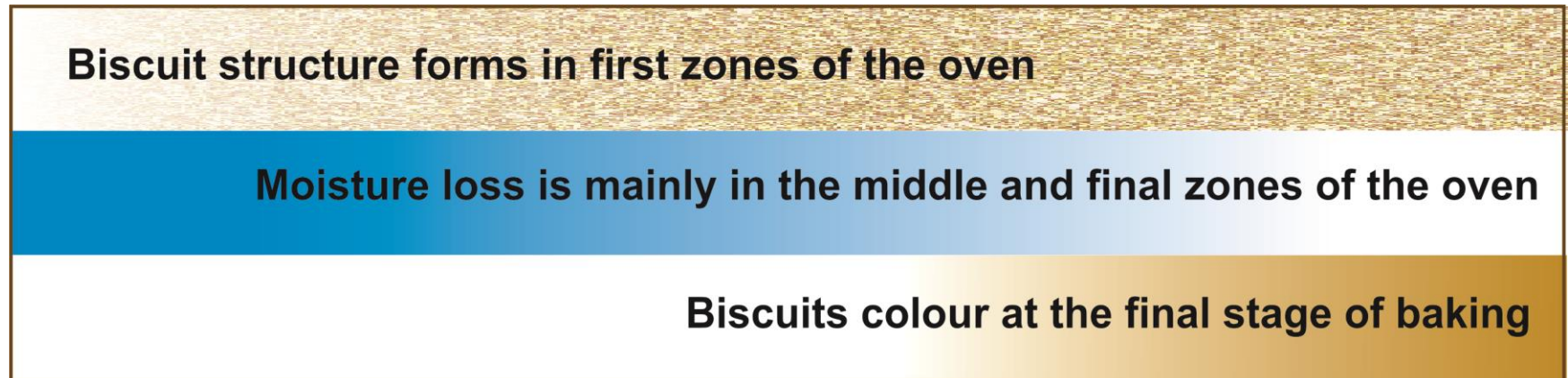

Start of baking

**Baking process** →

Finished bake

## Development of biscuit texture and structure

*Some of the complex chemical and physical changes which take place are heat dependent and occur during baking. Water in the dough plays a vital role.*

- Hydration of proteins in the flour allows the gluten to form and develop
- Gluten swells and forms a web which can hold gas and air bubbles. The swelling occurs at 30 – 50°C and gluten coagulates at over 70°C
- Air bubbles in the dough are saturated and expand by up to 50% at 95°C
- Hydrated starch begins to gelatinise at 50 – 60°C
- Leavening agents: ammonium bicarbonate reacts rapidly around 60°C

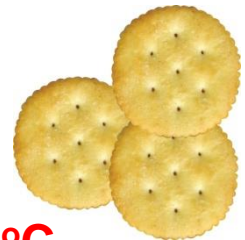
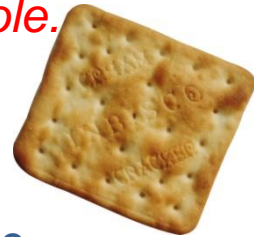

**Biscuit structure is formed when the dough pieces reach 75 – 100°C  
(in the first zones of the oven)**

## Moisture removal from the dough pieces

*After the biscuit structure is formed, the free water is evaporated from the surface of the dough pieces.*

- Biscuit doughs typically have moisture contents of 5% - 15% and cracker doughs 15% - 25%.
- During baking the moisture content will typically be reduced to 1.5% - 2.5%
- At temperatures over 100°C, water will always be evaporated from the surface of the dough pieces

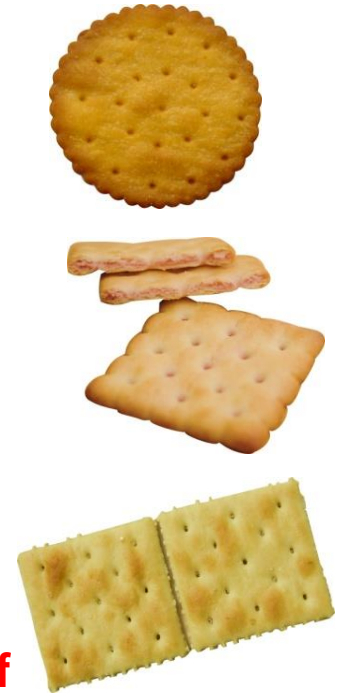

**Cracker ovens require high heat inputs in the middle zones of the oven to reduce final moisture levels to 1.5 – 2.0%**



## Colouring of the biscuits

*After the removal of moisture, the surface of the biscuit is dry and the temperature will rise quickly. The colour will change at temperatures over 150°C. There are 3 processes which develop the biscuit colour.*

- **Caramelisation.** This is a browning reaction caused by the breakdown of sugars at high temperatures (fructose 110°C, glucose and sucrose at 160°C)
- **Dextrinisation.** The breaking down of starch molecules at temperatures over 100°C produces pyrodextrins, which are brown in colour
- **Maillard reaction.** A complex chemistry caused by the reaction of sugars and amino acids. This is particularly evident where dough pieces have been brushed with milk.

**Colouring occurs in the final zones of the oven where the biscuit surface temperature is over 150°C**



## Oven profiles

*The oven profile for temperature and humidity must be designed to provide optimum conditions at each stage of the baking process.*

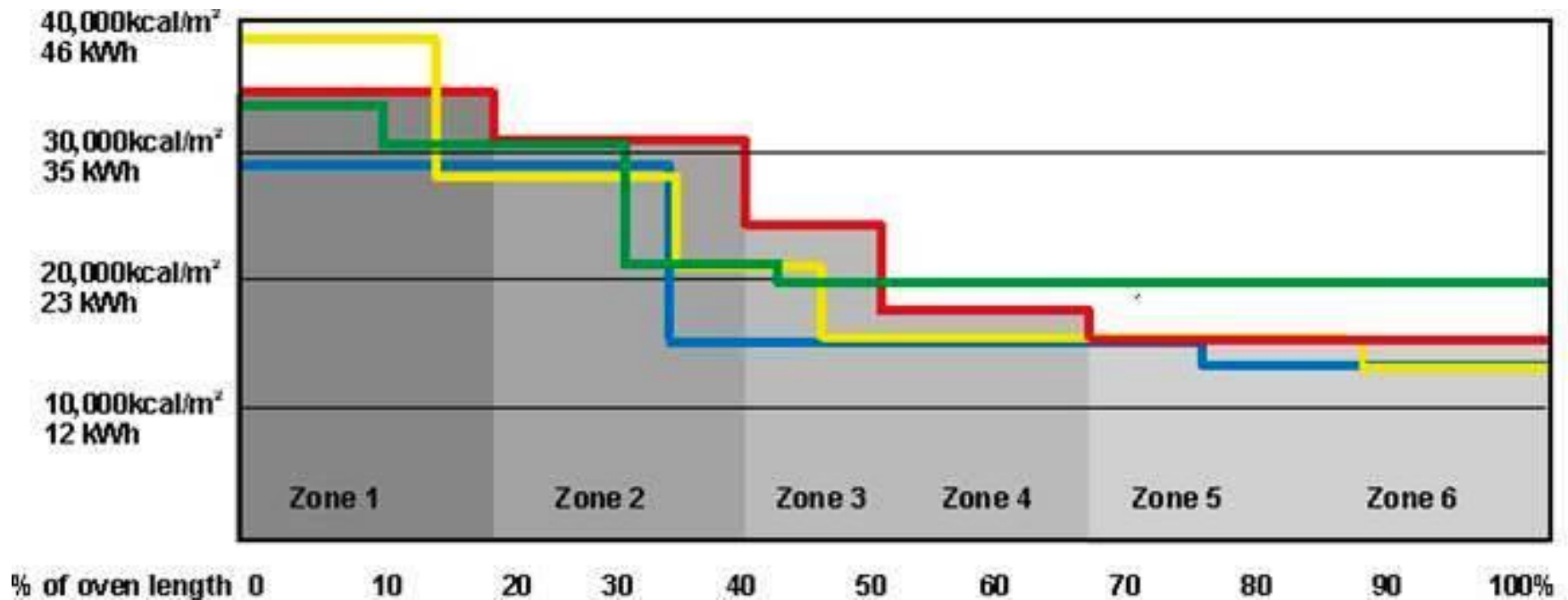

### There are 3 methods of heat transfer

#### ■ Radiation

Infra-red radiation is the most important heat transfer method for biscuit baking. Radiation is stable, penetrative and flexible and is essential in creating good structure and texture of the biscuits



#### ■ Conduction

Conduction transfers heat from the area of higher temperature to the area of lower temperature. Conduction is particularly important when baking with pre-heated heavy mesh CB5 bands and steel bands.



#### ■ Convection

In convection ovens jets of hot air are blown onto the surface of the products. The impingement of hot air is particularly effective in drying the dough pieces





### Direct gas fired ovens

#### *baking by infrared radiation*

- Direct gas fired ovens are very widely used. They offer versatility to bake any type of biscuits, cookies and crackers.
- Heat transfer is by radiation from the burners and the baking chamber walls

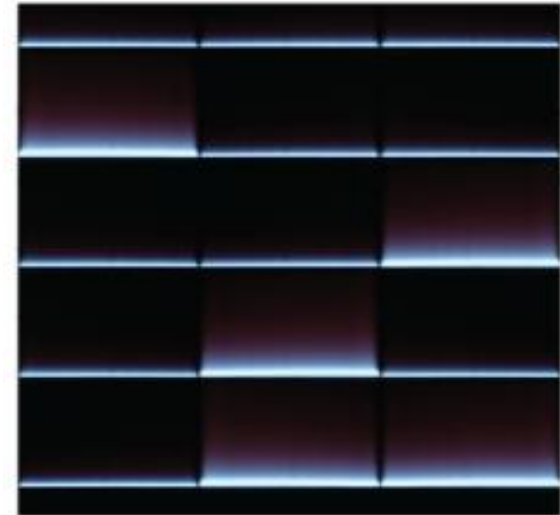
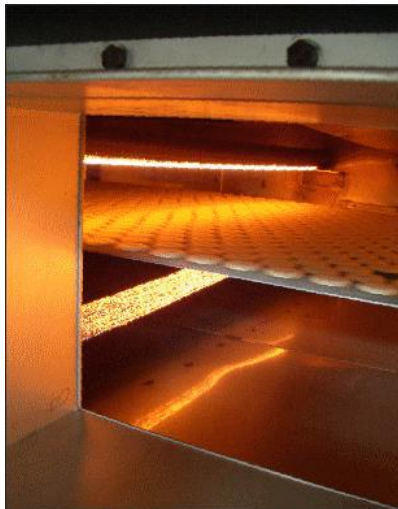

### Indirect Radiant Ovens

*baking by infrared radiation*

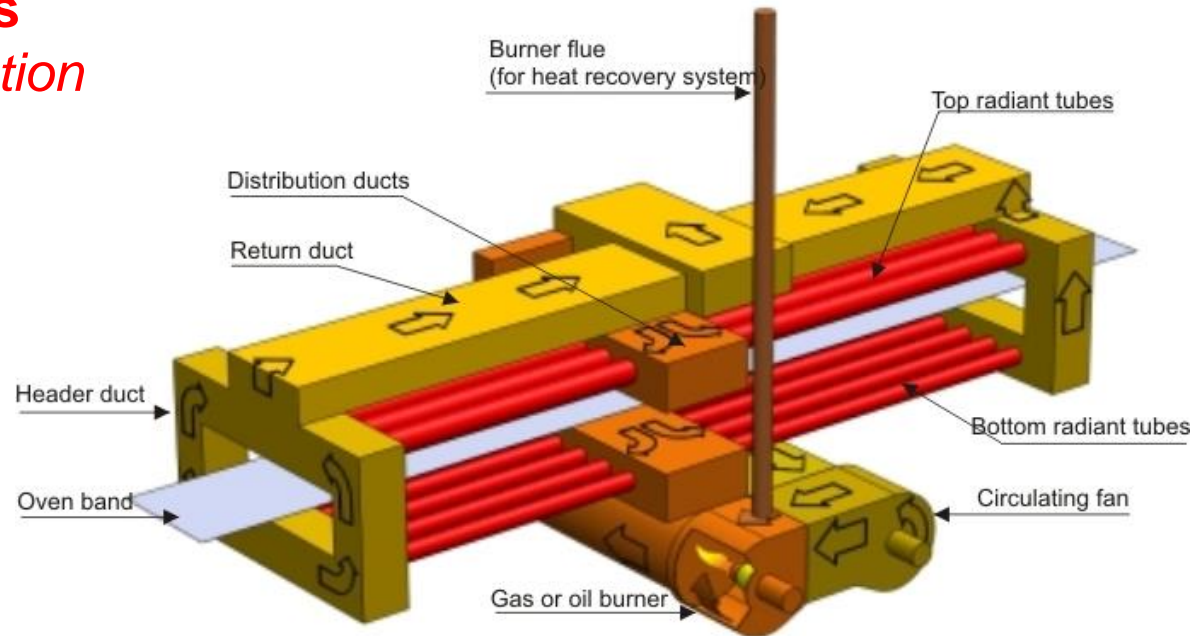

- Indirect radiant (cyclotherm) ovens are constructed in separate zones. Each zone is 10-20m long and has a single burner, heat exchanger and circulation system for the hot gases from the burner.
- The hot gases are circulated by a fan through radiant tubes above and below the band and then are returned via the fan to the burner tube. It is essentially a closed radiant heat transfer system

### Conduction from the oven bands

- Conduction transfers energy from an area of high temperature to an area of lower temperature and acts to equalise the temperatures.
- Heat transfer by conduction from hot steel oven bands and Compound Balanced Weave bands is important for baking cookies and crackers.



### Convection baking

- Convection is the movement occurring in a fluid medium, for example the air in the baking chamber.
- Convection baking refers to heat transfer by the impingement of jets of hot air onto the dough pieces and the oven band. Baking is controlled by altering the temperature of the hot air

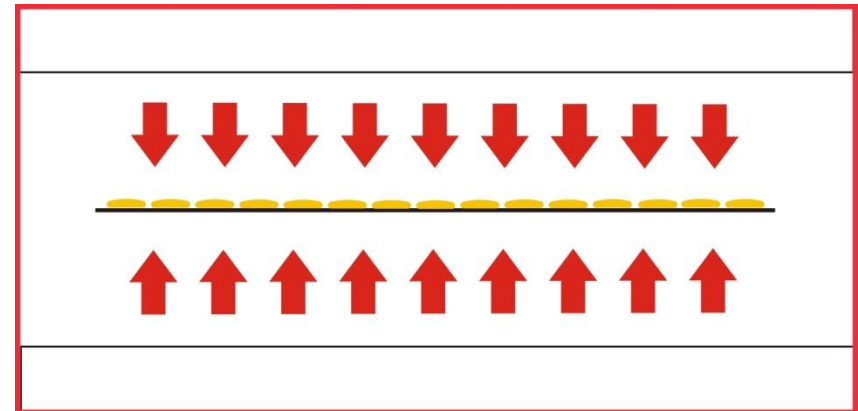



### Convection Ovens

- Convection ovens are constructed in zones, each zone having a single burner and circulation fan. The fan blows air around the burner tube where it is heated and then through ducts above and below the oven band. From these ducts jets of hot air are blown on to the products.
- Hot air from the baking chamber is drawn back to the fan to be re-circulated.
- The baking system may be direct or indirect. Indirect fired ovens have a multi-pass heat exchanger

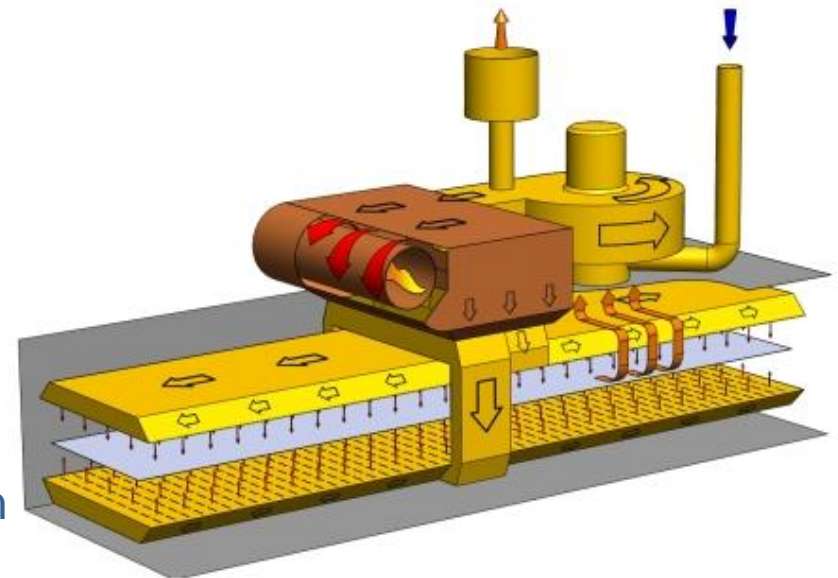

*Direct Convection Oven after Haas-Meincke*

### Extraction systems

- All ovens require a system to remove moisture from the baking chamber as the dough pieces are dried to a low final moisture content.
- The air and moisture in the baking chamber are drawn through an extraction fan to a flue (chimney) which expels the wet air from the bakery.
- The amount of extraction from the baking chamber is controlled by a damper or by a variable speed fan



*Extraction fan on a DGF oven*



### Oven efficiency with Heat Recovery System



- Of the heat loss through the burner flues, up to 50% can be recovered and used for baking in a **Heat Recovery System**
- In this Baker Pacific oven installation, the **Heat Recovery System** reduced the energy requirement by 15%

*(as calculated by an independent test)*

**bakerpacific**

## Oven efficiency with Heat Recovery System

Product	Oven type	Oven size	kWh/kg of biscuits
Rotary moulded	Indirect Radiant + HRS	1.2m x 100m	0.404
Rotary moulded	DGF/convection	1.2m x 60m	0.430
Rotary moulded	DGF/convection	1.5m x 100m	0.441
Rotary moulded	Indirect Radiant	1.2m x 100m	0.475
Rotary moulded	DGF/cyclotherm	1.2m x 60m	0.492
Snack cracker	DGF/convection	1.2m x 90m	0.477

### Why build the oven locally?

The cost of a quality imported baking oven will be approximately 40% of the total cost of a cracker line and up to 50% of the cost of a short dough biscuit line.

Many international manufacturers of high quality large ovens are located in high cost environments, Europe, USA, Japan, Korea. Local manufacture offers important cost savings.



*1.2m x 100m Indirect Radiant oven built in India*

### Baker Pacific build ovens in Asia, local to our customers

- Reduced fabrication cost
- Reduced import duties
- Low shipping cost
- Oven assembly in a low cost environment
- Part payment in local currency
- Establish local service capability



*Steel fabrication in China*



### The tasks

- Drawings
- Purchasing
- Contractors
- Shipping
- Installation

### Baker Pacific have a small engineering team

- **Project manager**  
Mechanical engineering, biscuit production, purchasing
- **Design engineer**  
Mechanical engineering design, Software: CAD/CAM, Solid Works. Steel fabrication experience, Pneumatic systems, conveyor drives / transmissions
- **Electrical Engineer**  
Control and safety systems and components, drives and transmissions, PLC and PID system software  
Commissioning experience
- **Local manager**  
Language, technical, commercial, financial experience
- **Installation engineer**  
Fabrication / installation experience



## Design layout drawings

Layout drawings are produced in Solid Works and Corel Draw to set out the design concept. Oven drawings are then made to meet the customer's requirements. Following agreement, a drawing is made showing foundations and installation details

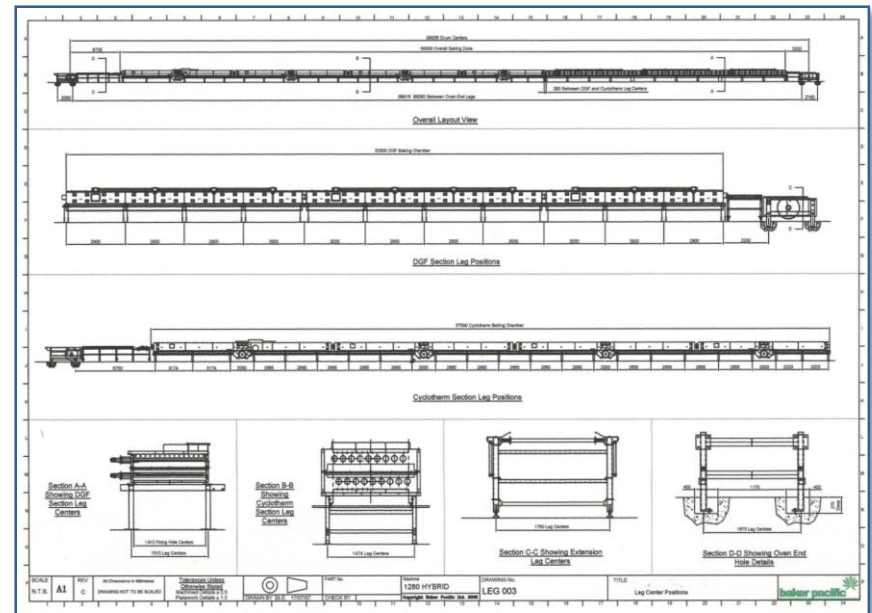
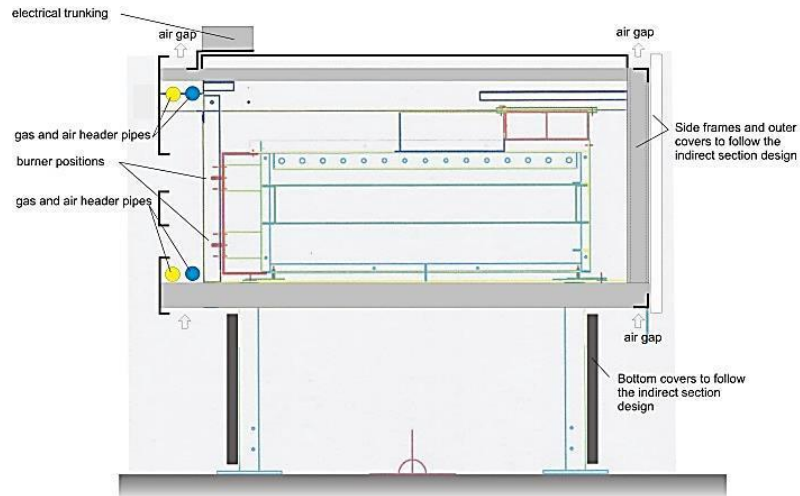



## Manufacturing drawings

The assemblies and parts are drawn in Solid Works with 3D pictures. The software allows us to check all dimensions and the assembly of parts.

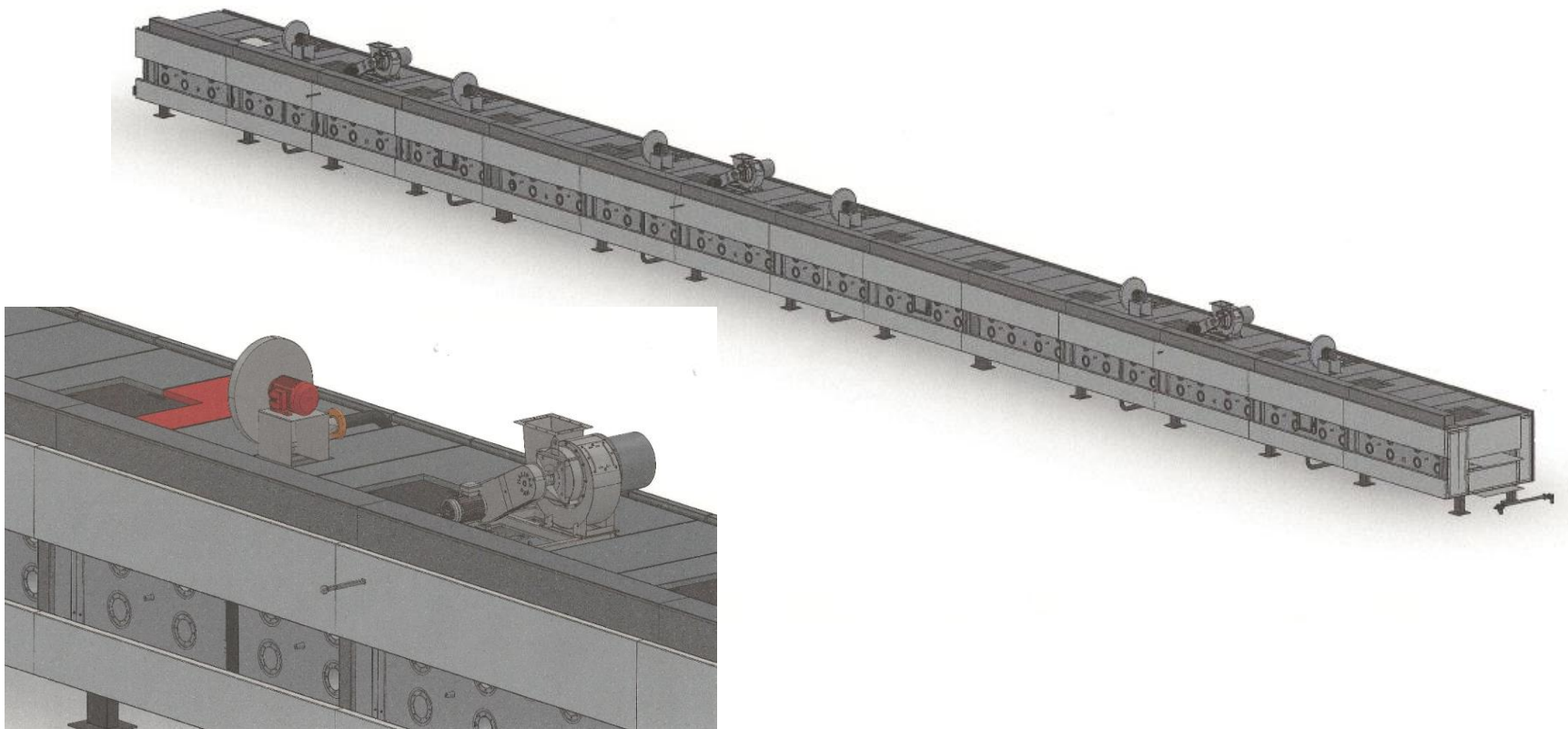

## Manufacturing drawings: Solid Works

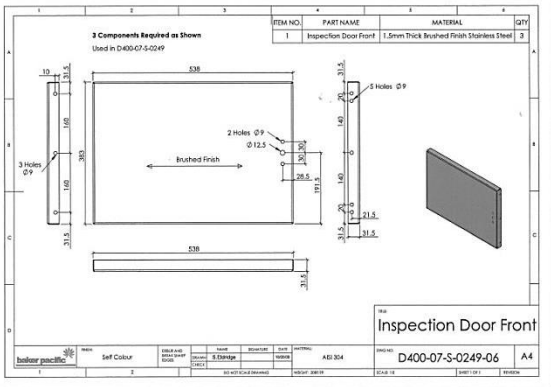
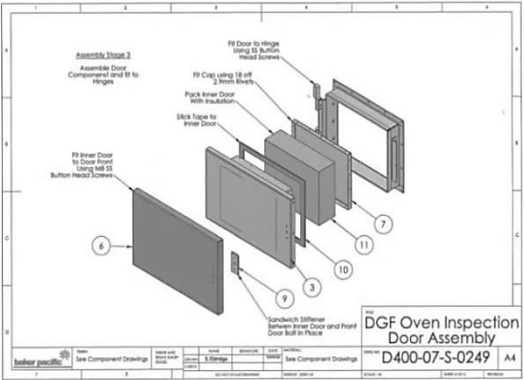
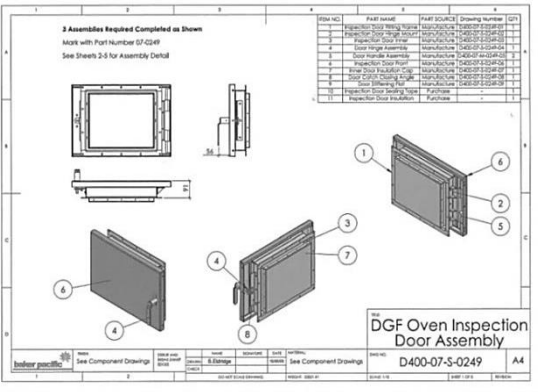
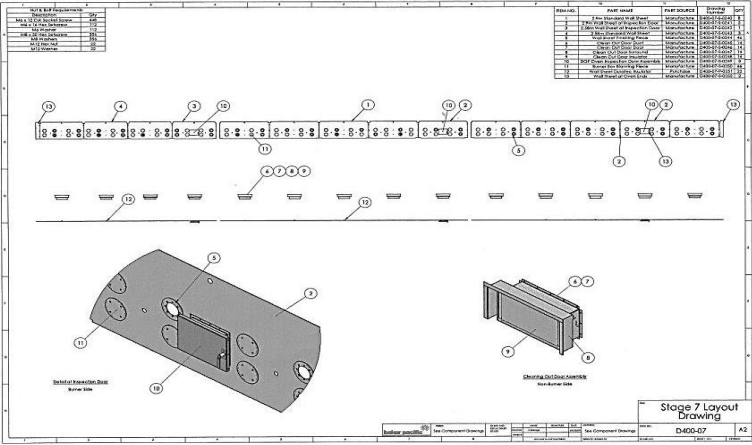
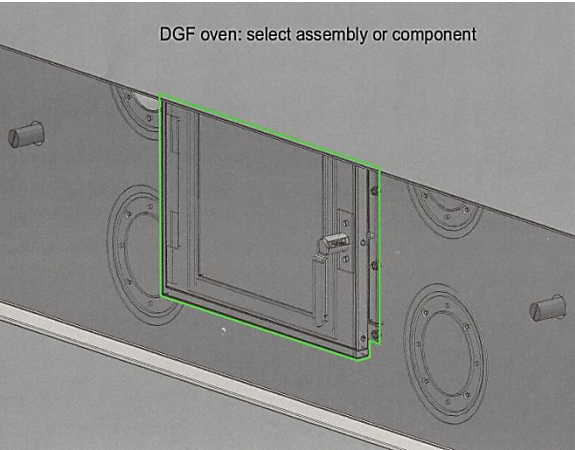

## Electrical drawings

These are produced as wiring diagrams with parts lists followed by AutoCAD drawings for approval and inclusion in the Operation Manual. The panels shown are built by Qiyuan company in Shanghai.

PLC software is provided by a specialist contractor





## Contractors

- Location /communication /factory space
- Capabilities: steel fabrication and assembly
- Quality standard for food industry
- Drawing standards and language
- Purchasing of materials and components



*India*



*Indonesia*



*China*

## Purchasing

Purchase Orders are placed on our contractors and suppliers detailing specification, price, terms of payment, delivery and commercial terms, for example guarantees. Currency may be in USD, Euro, GBP, RMB.....

- Bearings
- Burners
- Clamping elements, chains .....
- Electrical equipment, PLC
- Motors and gearboxes
- Fans and Blowers
- Gas equipment
- Insulation and seals
- Oven bands
- Pneumatic equipment
- Powder coatings



## Shipping

Our shipping has been managed by PT Geodis Wilson and DFS. They arrange pick up from our contractors anywhere in the world, shipment and delivery CIF. For shipments from China and India we use a local Trading Company to provide the export documentation.





### Oven installation

Baker Pacific provide two supervisory engineers for installation and commissioning. They supervise the work carried out by local contractors provided by our customer.

The oven is delivered in 'kits of parts' corresponding to the sequence required for the installation



# Designing and building baking ovens

# Oven installation



**Direct Gas Fired Oven**



**Indirect Radiant Oven**



**bakerpacific**

- The baking oven represents the major part of the investment for a cookie and cracker production line.
- The major suppliers internationally manufacture in high cost environments in Europe, USA and Asia. There are major cost benefits in establishing a capability for local manufacture.
- A small team of engineers is required. Most medium to large biscuit manufacturers and oven suppliers will have suitable capability.
- At Baker Pacific we continue to provide technical support , design and manufacturing drawings for local manufacture

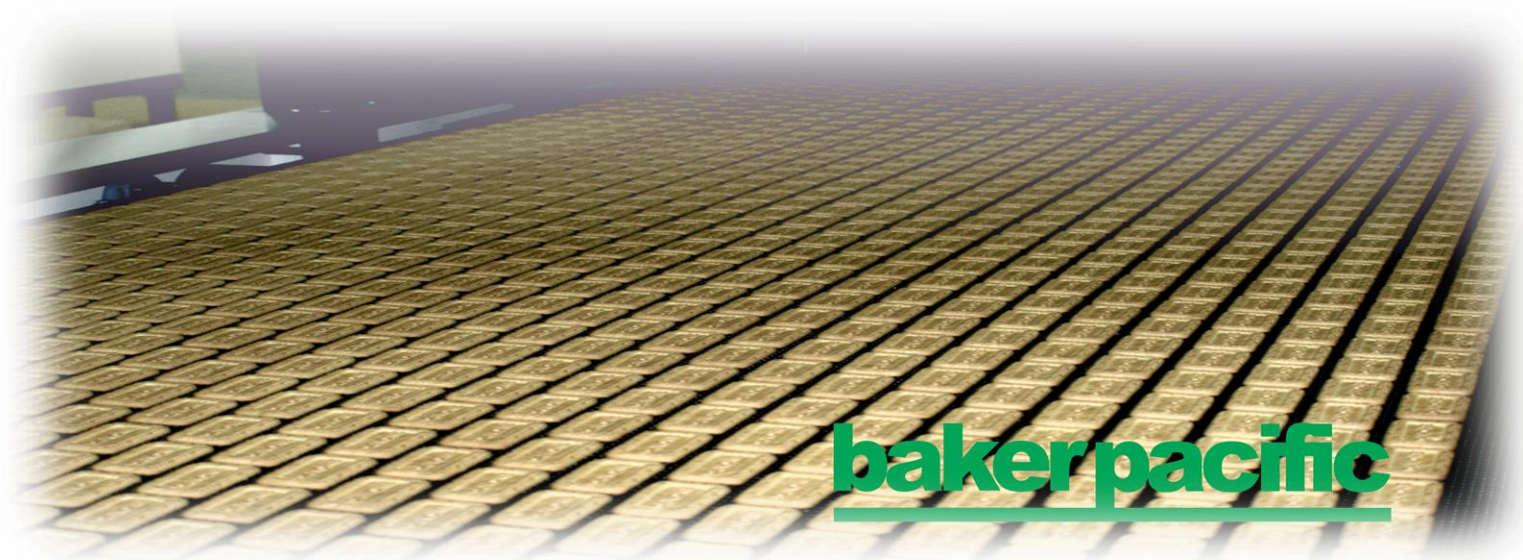



## How to Build a Biscuit Oven

*Direct Gas Fired Ovens for Industrial Production*

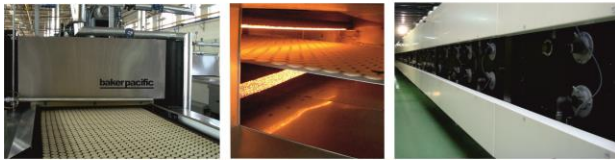

### S Eldridge Design Ltd.

Contact: Stephen Eldridge

37 Hazelwood Close, Honiton, Devon  
EX14 2XA, UK

Tel. +44 1404 45054

Email: [stephen.eldridge@btinternet.com](mailto:stephen.eldridge@btinternet.com)

Web-site: [www.build-a-biscuit-oven.com](http://www.build-a-biscuit-oven.com)

**Baker Pacific Ltd.**, 12/F Henley Building, Suite 7443, 5 Queen's Road Central, Hong Kong  
Tel. 852 2522 1114 Fax. 852 2521 1190 email [bakerman@bakerpacific.net](mailto:bakerman@bakerpacific.net)

[www.bakerpacific.net](http://www.bakerpacific.net)

[www.bakerpacific.com.hk](http://www.bakerpacific.com.hk)

**bakerpacific**